

Universal Gas Detector PEK850



Applications

- Low cost of ownership
- Wide range of sensors
- Flexible installation options
- Rugged and reliable
- Highly versatile

Specifications

Size	156x166x111mm	
Weight	Aluminium: 0.4 Kg Stainless Steel : 0.2kg	
Enclosure material	Aluminium and 316 Stainless Steel	
Ingress protection	Ip65	
Cable entries	2xM20	
Sensor types	Electrochemical	Catalytic
Operating temperature	-20 to +50 C (Sensor dependent)	-40 to +80 C
Humidity	15-90% RH	15-99% RH
Repatibility	<2% FSD(Typical)	
Response time	T90<15s Oxygen T90<30s to 120s Toxic	T90<3s
Operating voltage	9-30 VDC	
Display	OLED 128x128 pixels,green text on black background	
Power requirements	24mA maximum	300mA (Typical)
Electrical output	3-wire , 4-20mA (current source) warning and alarm signals are configurable RS-485 Modbus RTU	
Relay output	3 SPDT Relay rated 3 Amp at 24 VDC/120 VAC Relay configuration option Latching or non-Latching Rising or falling Configurable offset for alarm and warning Configurable on and off delays on alarm relays.	

Features

Easy and safe to use	Bright, clear display indicates gas level and detector status even in dark locations. Zero and calibration functions are performed via the display and magnetic wand
wide range of sensor	pellistor sensors, for all flammable detection needs including hydrocarbons, hydrogen and vapours containing halogens. Electrochemical sensor are used to detect a vast range of toxic gasses and oxygen.
Simple installation and maintenance	Sensors can easily be replaced using one hand without requiring tools or a hot work permit Detects when a sensor module is plugged-in and uploads the appropriate gas type, range, units and alarm levels
Sensor range selection	User can set the full-scale range of the sensor via the display menu according to site or specific location requirements.

Wiring

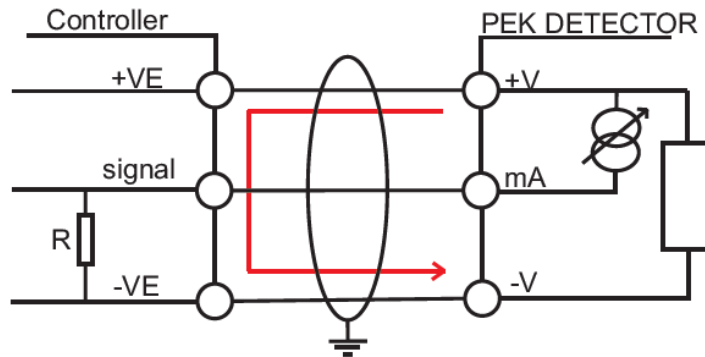

Source wiring

Gases and ranges

Gas	Range
Hydrogen sulphide(H ₂ S)	0-100ppm 0-200ppm
Oxygen(O ₂)	0-25% VOL
Methane	0-50% LEL
Hydrogen	0-50% LEL
Propane	0-50% LEL
n-Pentane	0-50% LEL

Choosing the gas detector for your needs

PEK offers different sensor concepts so you can choose exactly what you need for your site.

